

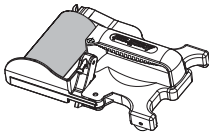

ACCUBRUSH XT CEILING EDGER

This edger is a pole-mountable paint edger that is part of the Accubrush family of products. It excels at painting long ceiling lines and can save hours of tedious cutting in at the top of the wall.

It is designed to be used in conjunction with the Accubrush MX Paint Edger, which is used around doors and windows.



Accubrush MX
Paint Edger

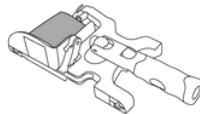

Accubrush XT
Ceiling Edger

FIRST TIME USING AN ACCUBRUSH?

Watch our how-to videos at start.accubrush.com or just point your camera at the QR Code to the right.



GETTING READY

THINGS YOU'LL NEED



Disposable Cup with
Water

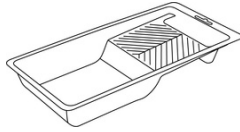

9" Paint Tray with Ramp or
5 Gallon Bucket with Grid

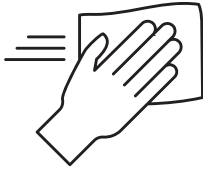
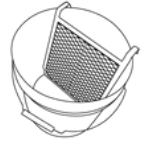

A Damp Rag



High Quality
Interior Latex Paint
(Well-stirred)

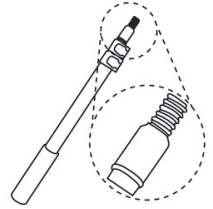

Paint Pole with
Standard Thread

BEFORE STARTING

GET FAMILIAR WITH THE TOOL

Before using this tool for the first time, we recommend working through these instructions without putting paint onto the roller. This will give you an opportunity to get familiar with the tool without risking getting paint on the ceiling.

GUIDE TO ACCUBRUSH PARTS

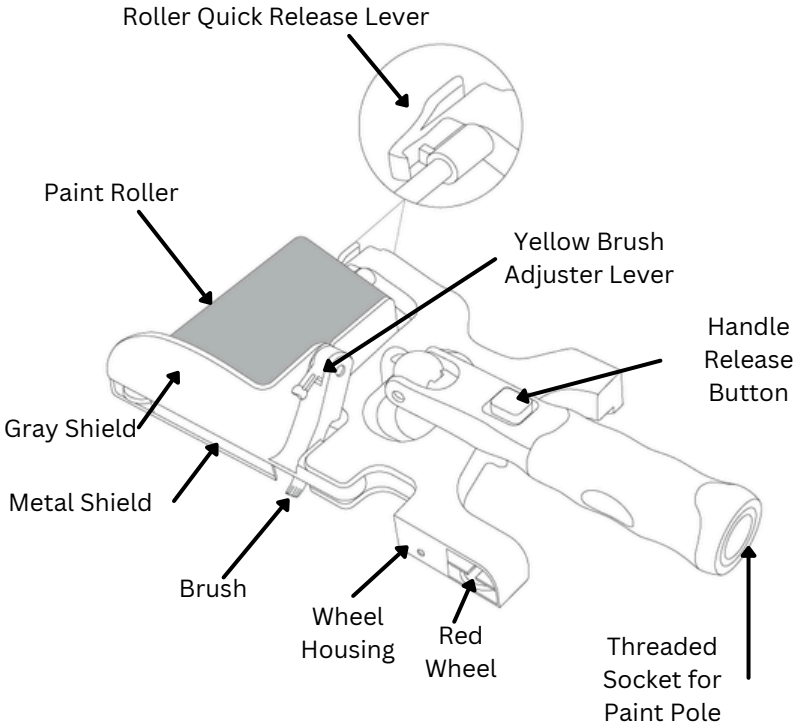

STEP ONE

LOAD THE PAINT ROLLER



Push handle down until it clicks into locked position.

LOADING THE PAINT ROLLER, CONTINUED

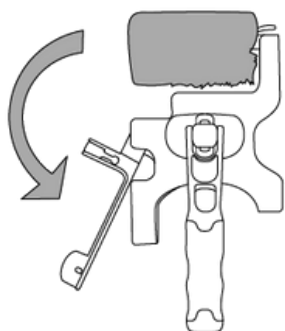

Open the gray shield.

If using a paint bucket, insert the paint pole into the handle before loading with paint.

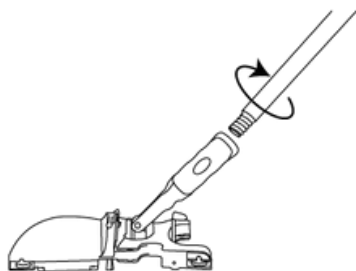

Turn edger upside down (red wheels facing up) and load paint in a 9 inch tray or paint bucket. Continue loading paint for at least sixty seconds until roller is fully loaded with paint.

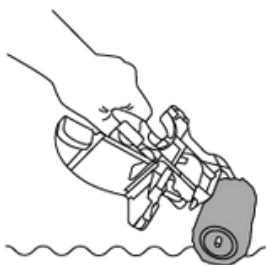

When properly loaded, you should not see any white (unpainted) fibers on the roller.

STEP TWO

TEST THE PAINT ROLLER

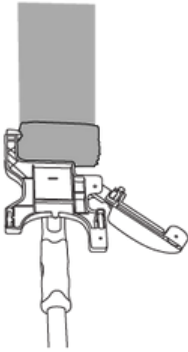

Find a space in the middle of your wall and turn the edger so that the red wheels are facing you. Paint a stripe on the wall.

Compare the stripe with the figures below to see if the roller is fully loaded.

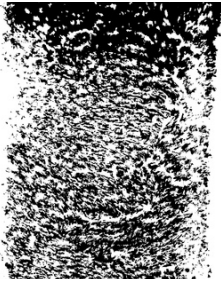

Not Enough Paint.
Load paint more heavily on the roller.

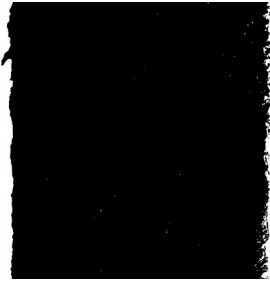

Your roller has enough paint.

STEP THREE

CLOSE THE SHIELD

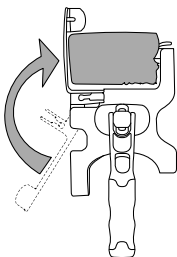

Close the shield.

STEP FOUR

WIPE OFF ANY STRAY PAINT

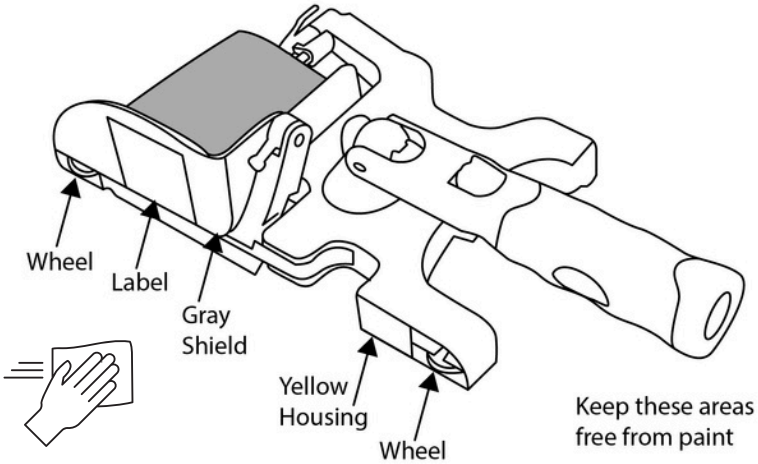

Take a look at the side of the edger which will be making contact with the trim.

Use a damp rag to wipe paint off of any of these parts of the edger that may have paint on them.

STEP FIVE

PUT EDGER ON A POLE

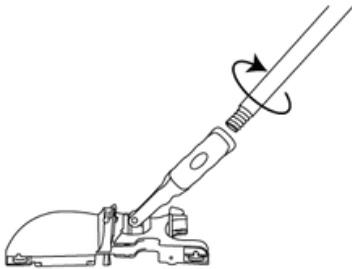

If you have not already done so, insert a paint pole into the handle.

You can use the XT edger without a pole, but using a pole is highly recommended.

STEP SIX

RELEASE HANDLE LOCK

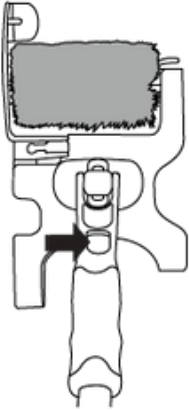

Press the handle release button to allow the handle to swivel freely.

STEP SEVEN

EDGE ALONG CEILING

Put the gray shield of the edger against the ceiling or crown molding.

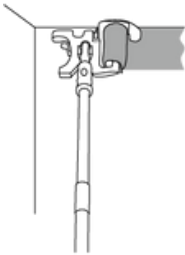

Stand away from the wall so that the paint pole leans in about 30 degrees.

Adjust the length of the pole so that the bottom of the pole is between waist-high and chest-high..

Keep the edger directly in front of you and step to the right and left, moving the edger with you in order to paint the line against the ceiling.

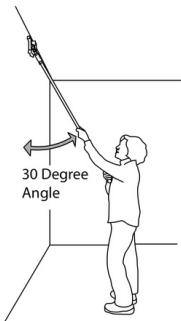

You should be able to fully cover the wall and get a good cut-in line in 2-3 passes. If you need more than 2-3 passes, load paint more heavily onto the roller.

End your painting with the roller stroke covering over any brush marks or wheel marks.

STEP EIGHT

FEATHER OUT THE PAINT

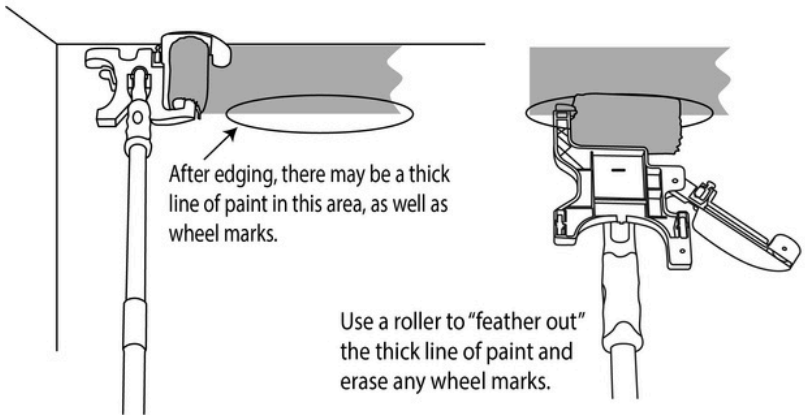

You may find that it is easiest to use your 9 inch roller to feather out this line of paint.

If you decide to use your Accubrush edger to do this:

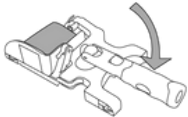

First, lock the handle in place by pushing it against the locking catch until it clicks into its locked position.

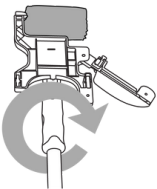

Second, rotate the paint pole so that the red wheels are facing you before applying pressure to the roller. This will keep the handle from coming unlocked when you paint.

INSIDE CORNERS

There are about 8 inches at the end of the wall that cannot be fully painted using the Accubrush. We recommend applying 12 inches of masking tape in these areas. Sealing the tape with painters caulk will help provide a clean edge in these corners.

SPECIAL CEILINGS

Acoustic (Popcorn/Cottage Cheese) Ceiling: The gray shield may knock cottage cheese off of the ceiling while painting. Test this unit against your ceiling before loading with paint.

Knockdown/Orange Peel/Textured Ceilings: Run your finger along the corner where the wall and ceiling meet. If it feels rough, use sandpaper to smooth down any bumps, and use painter's caulk to fill in any cracks. This will give you the smoothest line.

Depending on the thickness of the texture, you may need to extend the brush out slightly so that it reaches the ceiling.

ADJUSTING THE BRUSH

In most cases, you will want to make sure that the brush adjuster is in the HOME position. Once the lever is in the desired position, push the brush firmly into its socket to make sure it is fully inserted.

Lifting the yellow lever will make the brush extend further towards the trim. Do not go past the Maximum Extension shown.

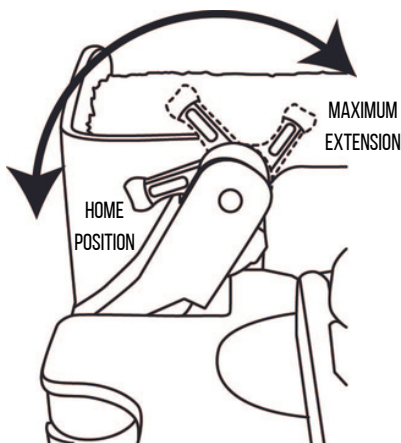

STEP NINE

TAKING A BREAK

Taking a break from painting? Keep your paint from drying out in the rollers and brush.

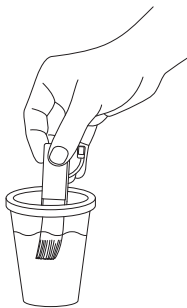

Remove the brush and rinse it out in a cup of water when you're taking a break.

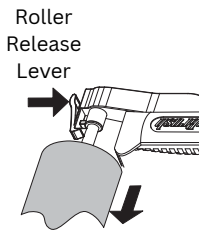

To remove the paint roller, push in on the roller release lever and tilt the edger until the roller slides off of the metal bar.

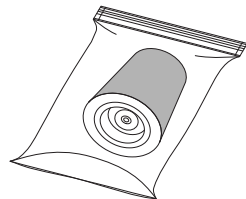

Place your loaded rollers into a plastic bag to keep them from drying out when you're taking a break, or even overnight.

STEP TEN

CLEAN UP

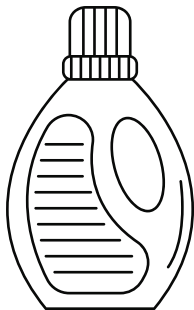

Our rollers and brushes are washable and reusable.

Need to get gunked-on paint off of your rollers and brushes? Mix 1/2 cup of fabric softener with 2 gallons of warm water and soak your rollers and brushes for ten minutes. Leave in longer if needed.

TROUBLESHOOTING TIPS

Problem	Try These Suggestions:
Missed Spots in paint on wall (sometimes called "Holidays")	<p>This is caused by the roller not laying down enough paint on the wall.</p> <ul style="list-style-type: none">• Take another pass with the edger.• Load paint more heavily onto roller.• Press more firmly when applying paint. If using the MX model, be sure to apply pressure at the bullseye.• Use multiple coats of paint on the wall.
Visible brush marks on wall next to the trim. Wheel marks next to trim. Thin unpainted line on wall about 1/4" from trim. (Shield marks)	<p>This is caused by the shield, brush or wheel leaving a line that is not filled in by paint from the roller.</p> <ul style="list-style-type: none">• Load paint more heavily on the roller.• On the final stroke, be sure that the roller is following the brush and use slightly less pressure so that the shield does not dig into the wall.• Replace the mini brush with a new one.• Use multiple coats of paint on wall (let paint dry between coats).
Wheel Tracks, about 4 inches from trim	<ul style="list-style-type: none">• Follow the instructions on page 8 regarding feathering out the paint and covering over these wheel marks
Cut-in Line is sharp but does not reach trim	<ul style="list-style-type: none">• Load paint more heavily onto the roller.• Extend the brush out slightly using instructions on page 9.

TROUBLESHOOTING TIPS, CONTINUED

Problem	Try This:
Cut-In Line is not sharp	<ul style="list-style-type: none">• Load paint roller more heavily.• Remove brush and clean it in a cup of water.• Replace mini-brush.
Paint Smeared on trim, about 1/2" away from wall.	You probably have paint on the shield or wheels that is transferring to the trim. <ul style="list-style-type: none">• Take a damp rag and carefully clean the shield, wheel housing, and wheels that will come into contact with the trim. (See page 6).
Cut-in Line has occasional small bumps 1-2mm high that are on the trim.	These bumps may be due to bumps in the line between the wall and the trim or ceiling. Run your finger along the line to see how rough the line is. Using caulk and/or sanding this corner should provide a smoother line. These “bumps” sometimes appear at the top and bottom of each stroke. <ul style="list-style-type: none">• Make longer strokes, of at least five feet in length to reduce these bumps.• Make sure roller is fully loaded with paint and reduce the number of passes that you use to paint the wall.
The edger is painting on the wall and the paint is extending too far up onto the trim.	<ul style="list-style-type: none">• Check to see that the brush adjuster lever is in the “home” position. See page 9.

Watch our how-to videos at start.accubrush.com or just point your camera at the QR Code to the right.

